

SoundGraffiti Dimmer Pack 4

Triac Module

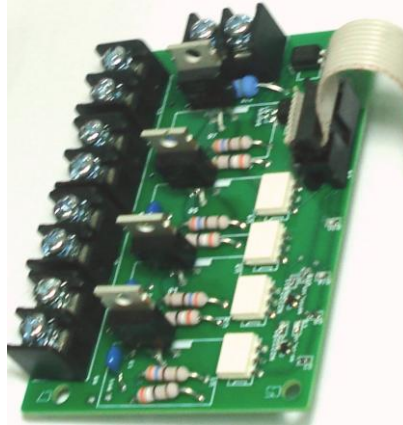

SoundGraffiti Dimmer Pack 4.1 Triac Module – 4channels module of voltage regulation (AC 110/220V) for lamps by signals from [Dimmer Pack 4 Base Module](#).

- Inputs galvanically isolated by optocouplers
- Four triac outputs

Specifications:

- Load: 24 to 240V AC, 0,5 A not cooled (max. 4A) per output
- Dimention : 90 x 64 x 30

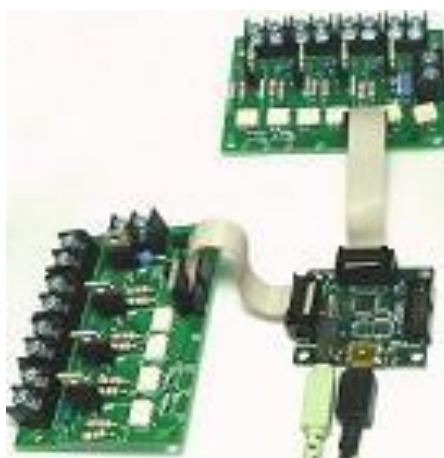

Fig 1. Connection 2 Triac Module to Base Module

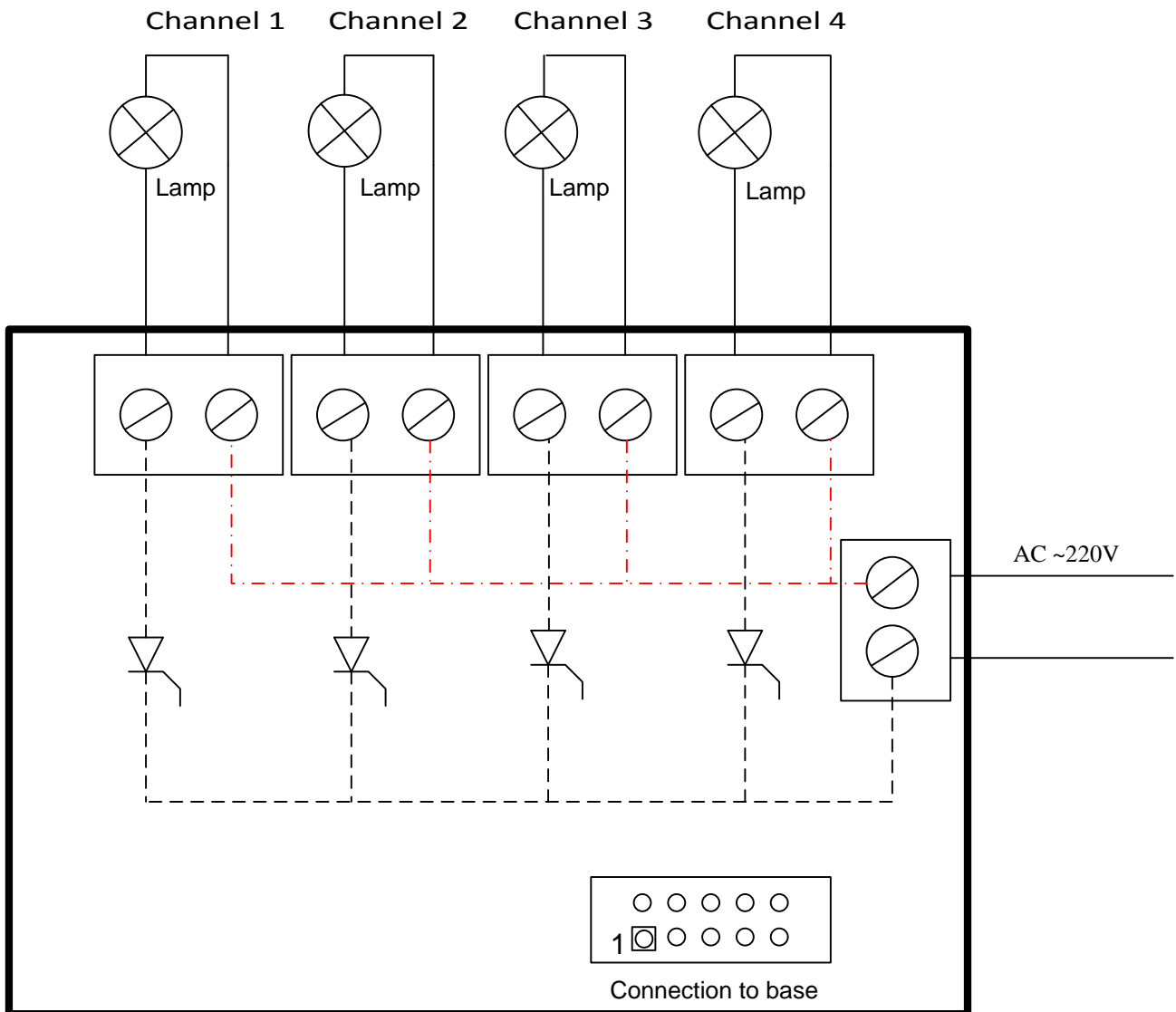

Fig 2. Block diagram Triac Module

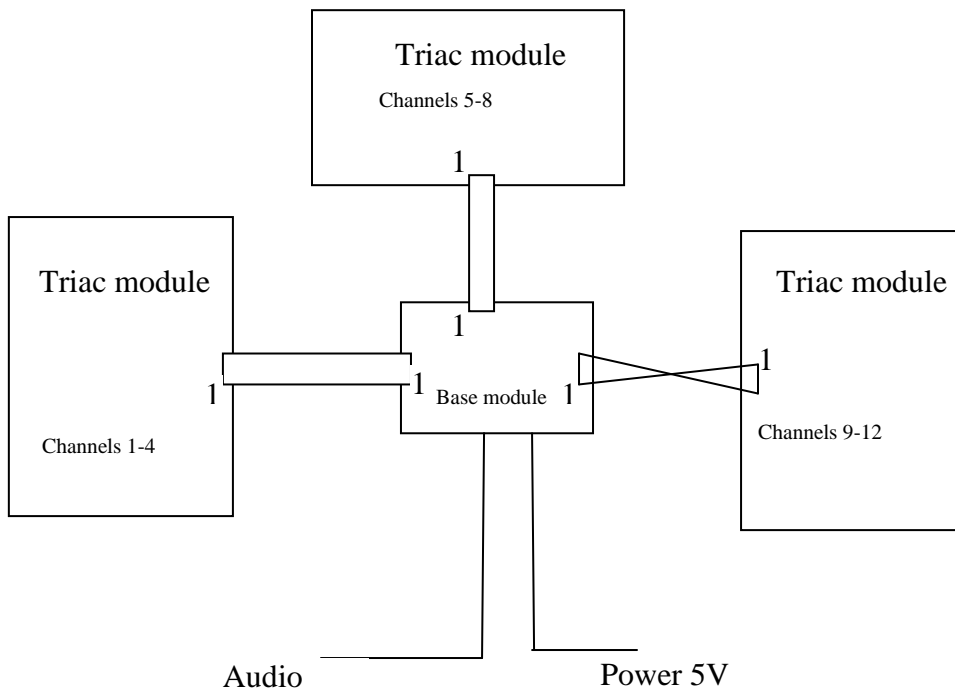

Fig 2. Connection Triac Modules to Base Module

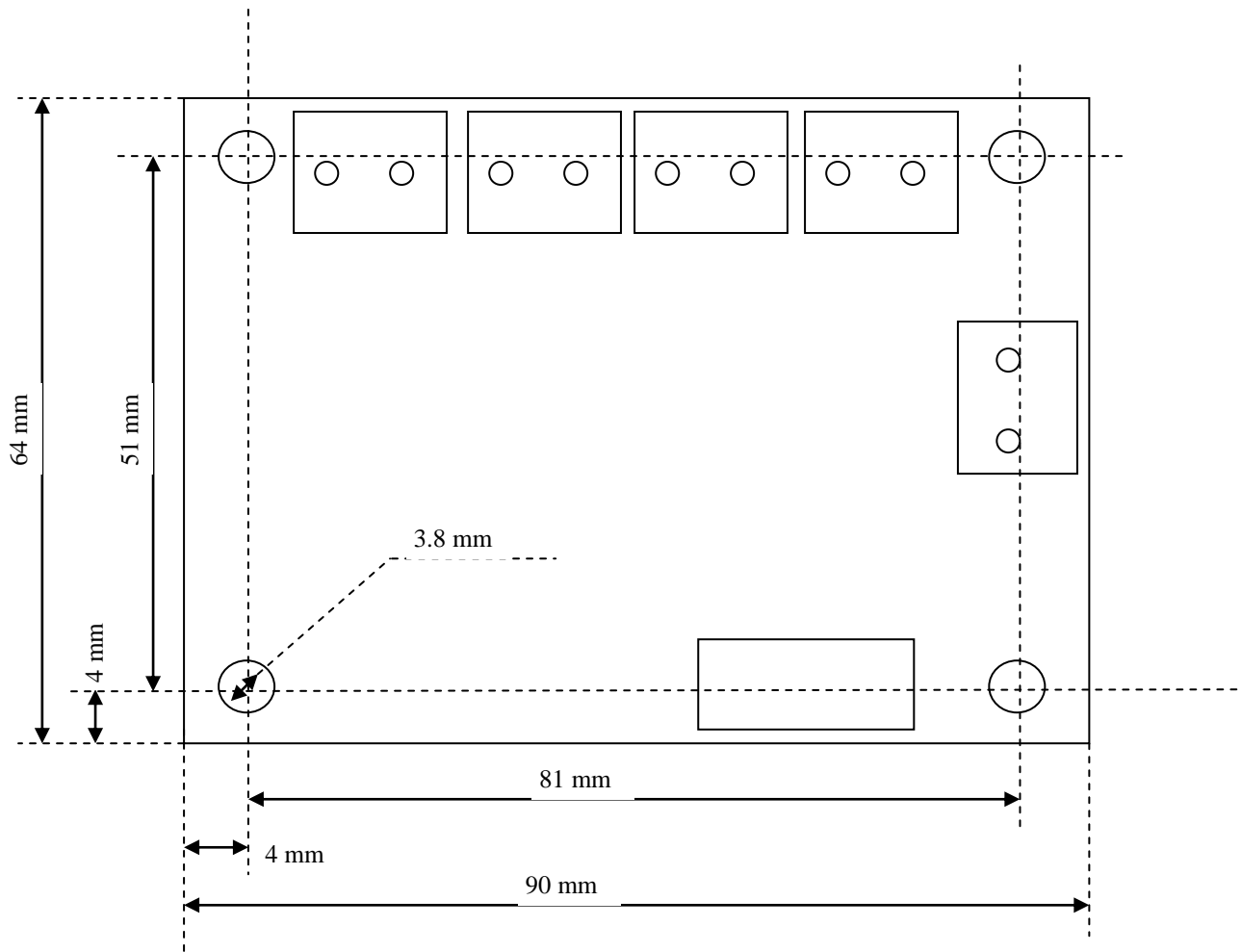

Fig 3. Dimentions

- **Input connector (Connection to base):** Rectangular headers, Male Pins 10POS, 2.54MM

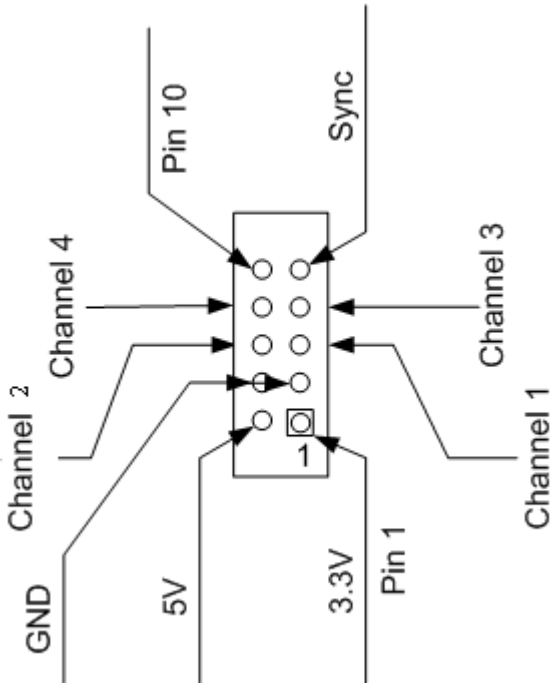

Fig 4. Input connectors Pins:

1. Output power 3.3 V
2. Output power 5 V
3. Ground
4. Ground
5. Channel 1 (input).
6. Channel 2 (input).
7. Channel 3 (input).
8. Channel 4 (input).
9. - None
10. Synchronization signal (output to base module)

Fig 5. Synchronization signal:

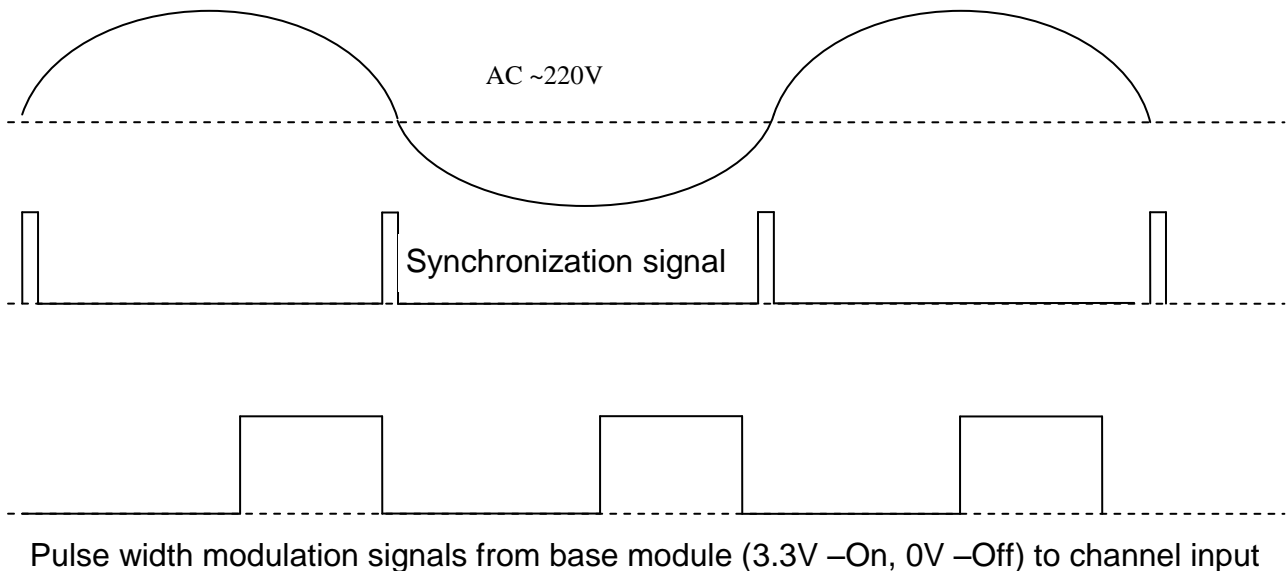

Fig 5. Schematic triac module:

